



**MOTOROLA**

RETROFIT INSTRUCTIONS

MCS 2000 RADIO  
SINGLE CONTROL HEAD  
TO  
DUAL CONTROL HEAD  
CONFIGURATION

MOTOROLA KITS  
H1698( ) and H1699( )



---

# Safety Summary

---

## Exposure to Radio Frequency Energy (National and International Standards and Guidelines)

Your Motorola two-way Radio, which generates and radiates radio frequency (RF) electromagnetic energy (EME), is designed to comply with the following national and international standards and guidelines regarding exposure of human beings to radio frequency electromagnetic energy:

- Federal Communications Commission Report and Order No. FCC 96-326 (August 1996)
- American National Standards Institute (C95-1-1992)
- National Council on Radiation Protection and Measurements (NCRP - 1986)
- International Commission on Non-Ionizing Radiation Protection (ICNRP - 1986)
- European Committee for Electrotechnical Standardization (CENELEC)
  - Env. 50166 - 1 1995E - Human Exposure to Electromagnetic Fields Low Frequency (0 Hz to 10kHz)
  - Env. 50166 - 2 1995E - Human Exposure to Electromagnetic Fields High Frequency (10kHz to 300Ghz)
  - Proceedings of SC211/8 1996 - Safety Considerations for Human Exposure to E.M.Fs from Mobile Telecommunications Equipment (M.T.E.) in the Frequency Range 30MHz - 6GHz (E.M.F - Electromagnetic Fields)

To assure optimal radio performance and that human exposure to radio frequency electromagnetic energy is within the guidelines set forth in the above standards, transmit *only* when people inside and outside the vehicle are at least the minimum distance away from a properly installed, externally-mounted antenna.

Table 1 below lists the minimum distance for several different ranges of rated radio power.

*Table 1 Rated Power and Distance*

<b>Rated Power of Vehicle-installed Mobile Two-way Radio</b>	<b>Minimum Distance from Transmitting Antenna</b>
7 to 15 Watts	1 Foot (30.5 Centimeters)
16 to 50 Watts	2 Feet (61 Centimeters)
More than 50 Watts	3 Feet (91.5 Centimeters)

---

## Mobile Antenna Installation

Install the vehicle antenna *external* to the vehicle and in accordance with:

- The requirements of the antenna manufacturer/supplier
- Instructions in the Radio Installation Manual

---

## Control Station Operation

When radio equipment is used to operate as a control station, it is important that the antenna be installed outside the building and away from places where people may be in close proximity.



**Refer to Table 1 on page 2 for rated power and minimum distance values for transmitting antennas.**

---

## Airbag Warning

### **VEHICLES EQUIPPED WITH AIR BAGS**

An air bag inflates with great force. DO NOT place objects, including communications equipment, in the area over the air bag or in the air bag deployment area. If the communications equipment is installed improperly and the air bag inflates, this can cause serious injury.

Installation of vehicle communication equipment should be performed by a professional installer/technician qualified in the requirements for such installations.

An air bag's size, shape and deployment area can vary by vehicle make, model and front compartment configuration (e.g., bench seat vs. bucket seats). Contact the vehicle manufacturer's corporate headquarters, if necessary, for specific air bag information for the vehicle make, model and front compartment configuration involved in your communication equipment installation.

---

## LP Gas Warning

It is mandatory that radios installed in vehicles fuelled by liquefied petroleum gas conform to the National Fire Protection Association standard NFPA 58, which applies to vehicles with a liquid propane (LP) gas container in the trunk or other sealed off space within the interior of the vehicle. The NFPA58 requires the following:

- Any space containing radio equipment shall be isolated by a seal from the space in which the LP gas container and its fittings are located.
- Removable (outside) filling connections shall be used.
- The container space shall be vented to the outside.

---

## Anti-Lock Braking System (ABS) and Anti-Skid Braking System Precautions



### WARNING

**Disruption of the anti-skid/anti-lock braking system by the radio transmitter may result in unexpected vehicle motion.**

Motorola recommends the following radio installation precautions and vehicle braking system test procedures to ensure that the radio, when transmitting, does not interfere with operation of the vehicle braking system.

### Installation Precautions

1. Always provide as much distance as possible between braking modulator unit and radio, and between braking modulator unit and radio antenna and associated antenna transmission line. Before installing radio, determine location of braking modulator unit in vehicle. Depending on make and model of vehicle, braking modulator unit may be located in trunk, under dashboard, in engine compartment, or in some other cargo area. If you cannot determine location of braking modulator unit, refer to vehicle service manual or contact a dealer for the particular make of vehicle.
2. If braking modulator unit is located on left side of the vehicle, install radio on right side of vehicle, and conversely.
3. Route all radio wiring including antenna transmission line as far away as possible from braking modulator unit and associated braking system wiring.
4. Never activate radio transmitter while vehicle is in motion and vehicle trunk lid is open.

### Braking System Tests

The following procedure checks for the most common types of interference that may be caused to vehicle braking system by a radio transmitter.

1. Run vehicle engine at idle speed and set vehicle transmission selector to PARK. Release brake pedal completely and key radio transmitter. Verify that there are no unusual effects (visual or audible) to vehicle lights or other electrical equipment and accessories while microphone is NOT being spoken into.
2. Repeat step 1. except do so while microphone IS being spoken into.
3. Press vehicle brake pedal slightly just enough to light vehicle brake light(s). Then repeat step 1. and step 2.
4. Press the vehicle brake pedal firmly and repeat step 1. and step 2.

5. Ensure that there is a minimum of two vehicle lengths between front of vehicle and any object in vehicle's forward path. Then, set vehicle transmission selector to DRIVE. Press brake pedal just far enough to stop vehicle motion completely. Key radio transmitter. Verify that vehicle does not start to move while microphone is NOT being spoken into.
6. Repeat step 5. except do so while microphone IS being spoken into.
7. Release brake pedal completely and accelerate vehicle to a speed between 15 and 25 miles/25 and 40 kilometers per hour. Ensure that a minimum of two vehicle lengths is maintained between front of vehicle and any object in vehicle's forward path. Have another person key radio transmitter and verify that vehicle can be braked normally to a moderate stop while microphone is NOT being spoken into.
8. Repeat step 7. except do so while microphone IS being spoken into.
9. Release brake pedal completely and accelerate vehicle to a speed of 20 miles/30 kilometers per hour. Ensure that a minimum of two vehicle lengths is maintained between front of vehicle and any object in vehicle's forward path. Have another person key radio transmitter and verify that vehicle can be braked properly to a sudden (panic) stop while microphone is NOT being spoken into.
10. Repeat step 9. except do so while microphone IS being spoken into.
11. Repeat step 9. and step 10. except use a vehicle speed of 30 miles/50 kilometers per hour.

---

## POTENTIALLY EXPLOSIVE ATMOSPHERES

Turn off your two-way radio when you are in any area with a potentially explosive atmosphere, unless it is a radio type especially qualified for use in such areas (for example, Factory Mutual Approved). Sparks in a potentially explosive atmosphere can cause an explosion or fire resulting in bodily injury or even death.

Areas with potentially explosive atmospheres include fueling areas such as: below decks on boats; fuel or chemical transfer or storage facilities; areas where the air contains chemicals or particles, such as grain, dust or metal powders; and any other area where you would normally be advised to turn off your vehicle engine. Areas with potentially explosive atmospheres are often but not always posted.

To avoid possible interference with blasting operations, turn off your radio when you are near electrical blasting caps, in a blasting area, or in areas posted: "Turn off two-way radio". Obey all signs and instructions.

# NOTES

---

# Retrofit Procedure

---

## Introduction



**The empty parentheses at the end of the kit numbers used throughout this publication stand for the alphabetical character (A, B, etc.) that denotes the revision level of the kit. The revision levels of the kits may change from time to time without affecting the validity of these installation instructions.**

This document provides installation instructions for a retrofit kit, which converts an *existing* remote mount single control head radio installation to one that has the dual control head option. A related publication (see next section titled *Reference Publications*) provides instructions for the complete installation of an MCS 2000 Mobile Radio equipped with the dual control head option (B800).

The dual control head option is available *only* for Model II and Model III low (12 or 15 Watt), mid (40 or 50 Watt) and high (110 Watt) radios that have remote mounted control heads (i.e., *not* dash mount configuration). The dual control head option enables an MCS 2000 mobile radio to be operated from two different locations (e.g., front and rear) in the vehicle in which it is installed. Both a control head and a loudspeaker are provided at the front and rear locations in the vehicle.

Operation of the dual control head configuration of the radio requires software release R04.04 or higher. A method to determine the software version installed in your radio is given on page 10.

The following are the major steps in the retrofit procedure:

- The main radio body, the trunnion-mounted front control head with handheld microphone and microphone hang-up clip, and the front loudspeaker are left in place in their original physical locations.
- A second trunnion-mounted control head with handheld microphone and hang-up clip is installed in the rear of the vehicle.
- A second trunnion-mounted loudspeaker, which is amplified and has a separate volume control, is installed near the second control head in the rear of the vehicle.
- The main (remote) cable, which interconnects the components of the single control head configured MCS 2000 radio, is replaced with a main (remote) cable assembly that interconnects all the components of the dual control head configured MCS 2000 radio.
- The new main (remote) interconnecting cable assembly includes an attached accessory plug, which plugs into the accessory connector on the bottom of the radio body.

- A new accessory plug is prewired to the new interconnecting cable assembly for the dual control head configuration. Therefore, the wiring for any accessories external to the radio, such as an ignition sense cable, emergency switch or pushbutton, and horn or light control relay, must be transferred from the original accessory plug to the one that is prewired to the new interconnecting cable.

---

Reference Publications

- GM 900, MC 900, GM 1200, MCX 1200, GM 2000, MCS 2000, MC 2100 Mobile Radios; Installation Instructions; All Frequency Ranges; Motorola Publication 68P02058U20 revision -E or higher.
  - Installation Instructions, MCS 2000 Radio with Dual Control Heads; Motorola Publication 68P81109C63
  - Service Instructions, Amplifier-Loudspeaker Motorola Kit HSN4035( ); Motorola Publication 68P81109C65-(-)
- 

Contents of Dual Control Head Retrofit Kits

The contents of the dual control head retrofit kit are listed in Table 2.

**Table 2: Contents of Dual-Control Head Retrofit Kits**

Motorola Kit/Identification/ Part No.	Description	Quantity
	Rear Control Head:	
HCN1119( )	Model II Radio Only (Kit H1698( ) Only)	1
SDHN4416( )	Rear Control Head Back Housing	1
HCN1120( )	Model III Radio Only (Kit H1699( ) Only)	1
SDHN4416( )	Rear Control Head Back Housing	1
HLN6615( )	Rear Control Head Mounting Hardware:	
0780127N02	Trunnion	1
0312002B14	Trunnion Mounting Screw, 10-16 X 1-In.	4
0305760W02	Wing Screw, M5.0 X 0.8 X 14.9	2
3205789W01	Cable Connector Gasket	1
HMN4069( )	Rear Microphone	
N/A	Hand Held Microphone (With Cable Assembly Attached)	1
0180757T98	Microphone Hang-up Clip Assembly	
	Clip	1



**Table 2: Contents of Dual-Control Head Retrofit Kits**

<b>Motorola Kit/Identification/ Part No.</b>	<b>Description</b>	<b>Quantity</b>
	Clip Mounting Screws	2
HSN4035( )	Rear Loudspeaker Assembly:	1
Part of Rear Loudspeaker Assembly	Rear Loudspeaker Body	
	Rear Loudspeaker Mounting Hardware Kit:	
0785977B02	Trunnion (Supplied Assembled to Rear Loudspeaker Body)	1
0300136756	Trunnion Mounting Screw, 10-16 X 5/8-In.	3
0305760W02	Wing Screw, M5.0 X 0.8 X 14.9 (Supplied Connected to Rear Loud- speaker Body)	2
HKN6141( )	Main Interconnecting (Remote) Cable Assem- bly (40 feet long)	1
HLN6412( )	Accessory Plug [Supplied Prewired to Main Interconnecting Cable Assembly HKN6141( ) listed above]	1

## Retrofit Procedure



Operation of the dual control head configuration of the radio requires software release R04.04 or higher. Before proceeding with the retrofit procedure, which follows, determine the software version installed in your radio using the procedure at the top of page 10.

## Determining Software Version Installed in Radio

1. Within 10 Seconds after powering on the radio, press the test mode entry button five times in quick succession. The location of the test mode entry button on Model II and Model III radios is illustrated below.

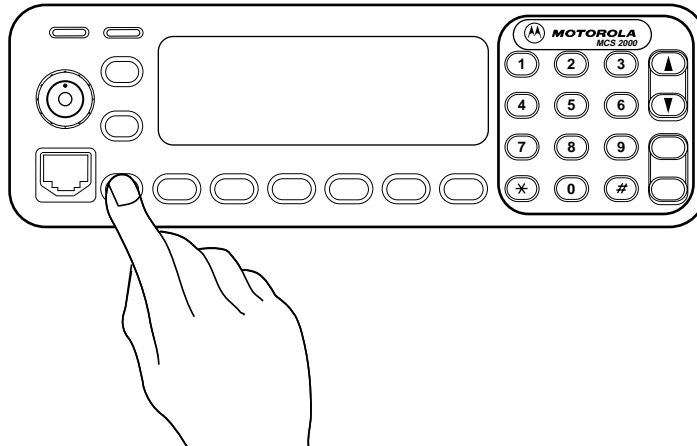

2. Immediately after pressing the test mode entry button five times, observe the display. The radio will scroll automatically and sequentially through the following displays:
  - SERVICE
  - The radio's software version (for example, R04.00)
  - The radio's control head version (for example, CNTLHD16)
  - The radio's model number (for example, M01UGN6PW6AN)
  - The radio's serial number (for example, 623AVU10026)
  - FLSHCD, followed by two or three screens of flashcode information
  - RF TEST



Before proceeding with the retrofit procedure, which follows, verify that all the contents of the Single Control Head to Dual Control Head Retrofit Kit, as listed in Table 2, are included in the packing box.

## Disassembly of Existing Single-Control Head Configuration

1. Disconnect hot (+) side of DC power cable from vehicle battery during retrofit process. *Do not* remove DC power cable from vehicle.
2. Refer to chapter 3 of installation instructions manual 68P02058U20-(). If radio is low or mid power version, refer to section titled *Mounting Trunnion Installation*. If radio is high power version, refer to section titled *Mounting Tray Installation*.
3. Remove the two wing screws that attach radio body to mounting tray or trunnion. Then slide radio body carefully out of trunnion or tray. Do not disconnect antenna connector from radio body or remove antenna from vehicle.



### Caution

In step 4 below, do not use any tools to tighten wing screws. Doing so will damage both radio body and trunnion or tray.

4. Unplug accessory plug on existing main (remote) interconnecting cable assembly from accessory connector on bottom of radio body. Then slide radio body back into trunnion or tray and replace wing screws temporarily.



Existing main (remote) interconnecting cable removed from vehicle in step 5 below is replaced later in this procedure with a new main (remote) interconnecting cable, kit HKN6141( ).

5. Disconnect existing main (remote) interconnecting cable from control head, loudspeaker, and radio body. Then remove cable from vehicle.

## Mounting Rear Control Head

1. Refer to Figure 1 on page 12 and, using control head trunnion 0780127N02 as a template, mark the locations for the four trunnion mounting screws on vehicle mounting surface.
2. Center punch the four locations, marked in step 1, and drill a 4-millimeter (0.16-inch) hole at each location.
3. Mount the control head trunnion to vehicle using the four supplied 10-16 by 1-inch sheet metal screws.



### Caution

In step 4 below, do not use any tools to tighten wing screws. Doing so will damage both control head and trunnion.



In addition to being identified by kit number, rear control head is identified by the words **REAR CONTROL HEAD** stamped on back housing. Front control head has no such marking.

4. If radio being retrofitted is a Model II, install control head kit HCN1119( ) in trunnion. If radio being installed is a Model III, install control head kit HCN1120( ). To install control head, slide it into trunnion until it snaps firmly into place. Then, start and *hand tighten only* the two wing screws that hold control head to trunnion.

5. Plug Telco plug, on cord of one of the hand-held microphones, kit HMN4069( ), into Telco jack on front of control head. Then use microphone to determine a suitable location for microphone hang-up clip.
6. Use the supplied microphone hang-up clip as a template and mark the locations for the two hang-up clip mounting screws.
7. Center punch the two locations, marked in step 6, and drill a 4-millimeter (0.16-inch) hole at each location.
8. Mount hang-up clip to the vehicle using the two supplied 10-16 by 1-inch sheet metal screws.
9. Slide button on back of microphone in hang-up clip.

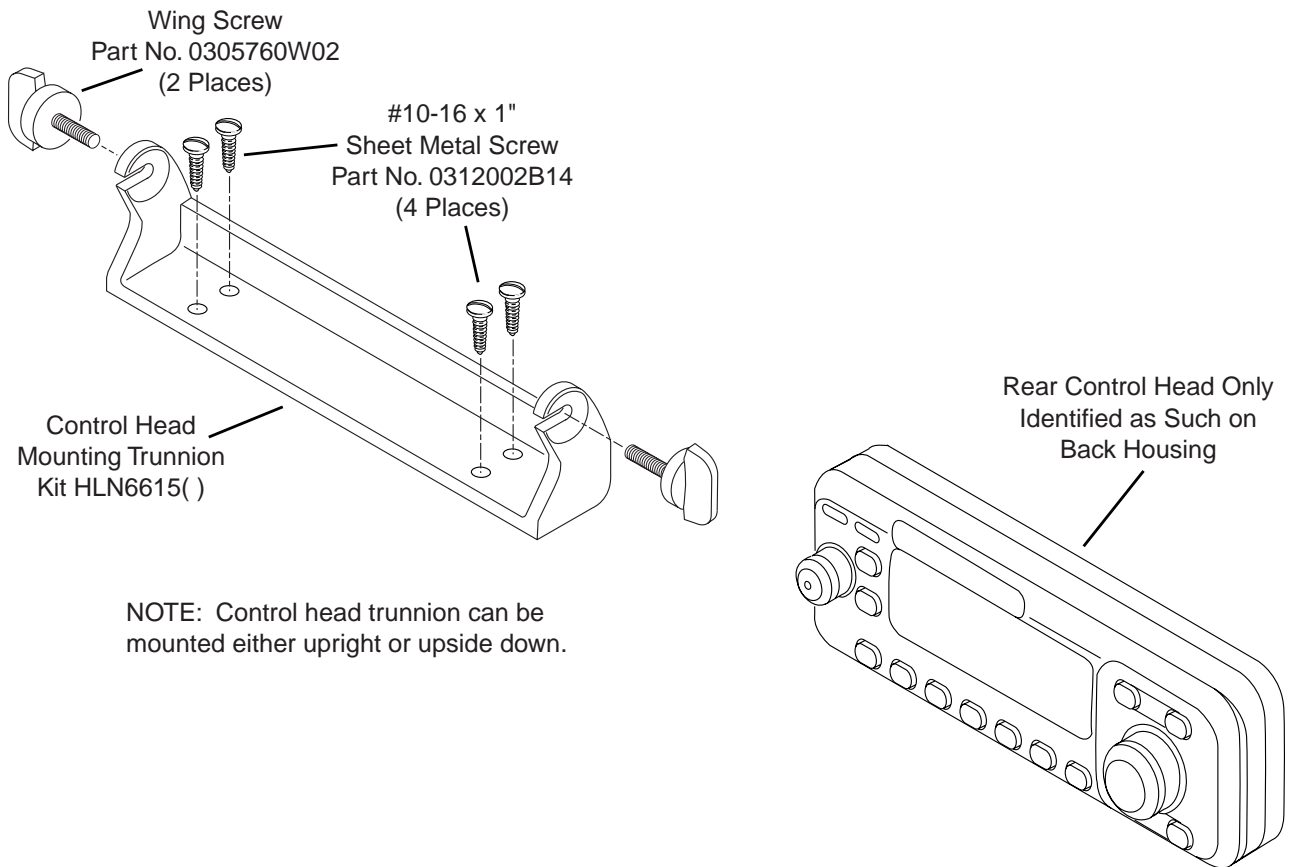

MAEPF-26471-A

**Figure 1 Mounting Rear Control Head**

## Mounting Rear Loudspeaker



Rear Loudspeaker kit HSN4035( ) has a 9-foot long connecting cable attached. Therefore, rear loudspeakers can be located up to 9-feet from rear control head. However, for operating convenience, it is best to locate the rear loudspeaker within a foot or two of the rear control head



Rear loudspeaker is field repairable. Refer to list of reference publications on page 8 for publication number of service manual. Front loudspeaker is not field repairable.

1. Refer to Figure 2 on page 14 and remove loudspeaker body from trunnion by removing the two wing screws that connect body to trunnion.
2. Using loudspeaker trunnion as a template, mark the locations for the three trunnion mounting screws on vehicle mounting surface. Then, center punch the three marked locations and drill a 4-millimeter (0.16-inch) hole at each location.
3. Mount trunnion to vehicle using the three supplied 10-16 by 5/8-inch sheet metal screws.



### Caution

In step 4 below, do not use any tools to tighten wing screws. Doing so will damage both loudspeaker and trunnion.

4. Slide loudspeaker into trunnion until it snaps firmly into place. Then, start and *hand tighten only* the two wing screws that hold loudspeaker body to trunnion.

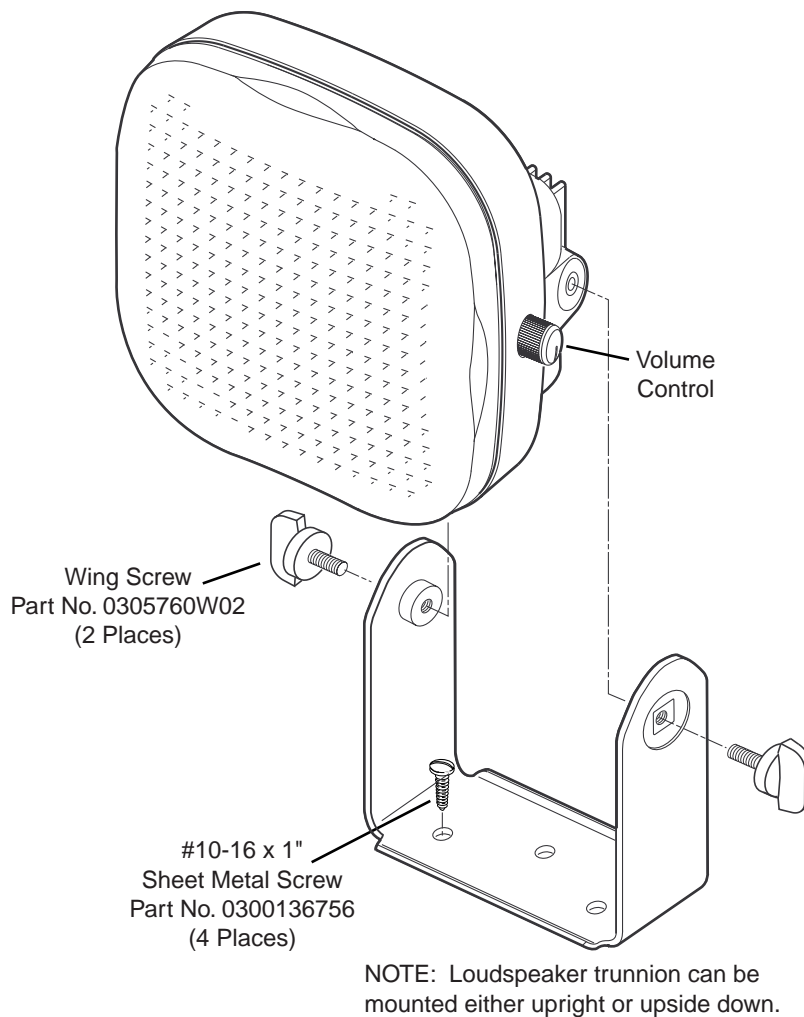

MAEPF-26476-A

**Figure 2 Installation of Rear Loudspeaker Kit HSN4035()**

## Interconnecting Cable Installation

The components of the dual control head configured radio are interconnected with main interconnecting cable, kit HKN6141(), which is 40-feet long. To interconnect the components of the dual control head radio, refer to Figure 3 on page 15 and proceed as follows:

1. Orient and route dual control head interconnecting cable in vehicle as illustrated in Figure 3.
2. Install connector gasket over connector on back of front control head.
3. Plug 18-pin front control head connector onto connector on back of front control head.
4. Plug connector on end of front loudspeaker cable into breakout with 2-pin connector.
5. Install connector gasket over connector on back of back control head.

6. Plug 18-pin rear control head connector onto connector on back of rear control head.
7. Plug connector on end of rear loudspeaker cable into breakout with 6-pin connector.
8. Install connector gasket over plug on front of radio body.
9. Plug 18-pin radio body connector onto recessed 18-pin plug on front of radio body.

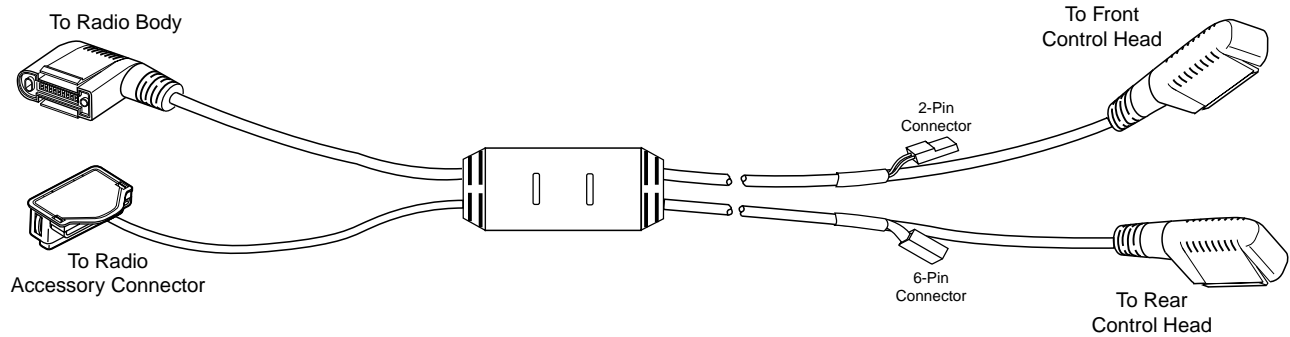

MAEPF-26465-O

*Figure 3 Interconnecting Components of Dual Control Head Radio*

## Connecting Accessories

1. Refer to the following topics in installation instructions manual 68P02058U20-().
  - a. In Chapter 4, section titled *Installation Instructions for Accessory Plug, MCS 2000 Radios Only*
  - b. In Appendix A1, table titled *2000 Series Accessory Connector Pin Functions*



**Accessory plug is supplied in retrofit kit already attached to main interconnecting cable assembly HKN6141().**

2. Disassemble accessory plug using disassembly procedure in section titled *Disassembling and Reassembling Accessory Plug* in Chapter 4 reference 1.a. above.





**Accessory plug supplied with retrofit kit is *not* wired internally as shown in Chapter 4 of Installation Instructions Manual 68P02058U20-(). Instead, it is wired as follows:**

1. A jumper (black) between locations 1 and 2
2. A jumper (black) between locations 4 and 9
3. Three wires from main interconnecting cable assembly connected to locations 10 (green), 11 (brown), and 14 (yellow)



### Caution

When performing steps 3 and 4 below, be certain that internal wiring of accessory plug remains in place as described in *Note* above.

3. Connect accessories to accessory plug in accordance with Appendix A1 table titled *2000 Series Accessory Connector Pin Functions* in reference 1.b. above.
4. Reassemble accessory plug using reassembly procedure in section titled *Disassembling and Reassembling Accessory Plug* in Chapter 4 reference 1.a. above.
5. Refer to chapter 3 of installation instructions manual 68P02058U20-(). If radio is low or mid power version, refer to section titled *Mounting Trunnion Installation*. If radio is high power version, refer to section titled *Mounting Tray Installation*.
6. Remove attaching wing screws. Then slide radio body carefully out of mounting trunnion or tray.



### Caution

In step 7 below, do not use any tools to tighten wing screws. Doing so will damage both radio body and trunnion or tray.

7. Plug accessory plug into accessory connector on bottom of radio body. Then slide radio back into mounting trunnion or tray.
8. Install attaching wing screws and tighten them securely.

### Reconnecting DC Power Cable

Reconnect hot (+) side of DC power cable to vehicle battery.



Motorola, ASTRO, Spectra, GM 900, MC 900, GM 1200, MCX 1200, GM 2000, MC 2100, and MCS 2000 are marks of Motorola, Inc.